

pureglow  
gas



# NOVO INSET

## HIGH EFFICIENCY GAS FIRE

### INSTALLATION AND USER INSTRUCTIONS

**All instructions must be handed to user for safekeeping**

Revision B - 11/09

Country(s) of destination - GB/IE

Pure Glow Limited • Stourvale Road • Lye • Stourbridge • West Midlands • DY9 8PP  
Tel: +44 1384 893060 • Fax: +44 1384 897728 • e-mail:info@pureglowltd.co.uk





*Novo Inset*

# INSTALLATION INSTRUCTIONS

Section	Contents	Page No.	Section	Contents	Page No.
1.0	<b>Important Notes</b>	1	7.1	Cable Fixing	9
2.0	<b>Appliance Data</b>	2	7.2	Checking the Burner & Spark Gap	10
3.0	<b>Installation Requirements</b>	2	7.3	Fitting the Fuel Bed (Euphoria models)	10
3.1	Room Sizing	2	7.4	Fitting Decorative Hood/Frame	11
4.0	<b>Site Requirements</b>	2	<b>8.0</b>	<b>Testing and Commissioning</b>	<b>11</b>
4.1	Ventilation	5	8.1	Operating the Appliance	11
5.0	<b>Unpacking the Appliance</b>	5	8.2	Setting Pressure	12
5.1	Component Checklist	5	8.3	Briefing the Customer	12
6.0	<b>Appliance Installation</b>	5	<b>9.0</b>	<b>Servicing</b>	<b>12</b>
6.1	Preparing the Appliance	5	9.1	Cleaning the Coals	13
6.2	Gas Supply Routes	6	9.2	Servicing the Burner Tray	13
6.3	Installation Method 1	6	9.3	Pilot Assembly	13
6.4	Installation Method 2	7	9.4	Catalyst	14
6.5	Installation Method 3	8	9.5	Testing for Firebox Leakage	14
6.6	Installation Method 4	9	<b>10.0</b>	<b>Troubleshooting Guide</b>	<b>15</b>
7.0	<b>Final Fitting</b>	9		<b>User Instructions</b>	

## 1.0 IMPORTANT NOTES

This appliance is a high efficiency, flueless catalytic flame effect gas fire. It provides radiant and convected warmth both efficiently and safely utilising the latest type catalytic converter and burner technology. The appliance does not require a flue system of any type as the catalytic converter cleans the flue products to provide a complete combustion system, which is intrinsically safe. It is designed to operate on Natural Gas (see data badge) and is factory set for operation on the gas type, and at the pressure stated on the appliance data plate.

The appliance incorporates a combustion monitoring system (Oxygen Depletion System). It must not be adjusted or put out of operation. If replaced then manufacturer's original parts must be used.

It is the LAW that all gas appliances and fittings are installed by a competent person and in accordance with the Gas Safety (Installation and Use) Regulations 1998, the relevant British Standards for Installation, Codes of Practice and the Manufacturers' Instructions.

At the time of writing, Gas Safe registered operatives are the only class of person considered as 'competent' by the HSE under the above regulations. The installation shall also be carried out in accordance with the following:

- Manufacturers' Instructions.
- The Building Regulations issued by the Department for Communities and Local Government, the Building Standards (Scotland) (Consolidation) Regulations issued by the Scottish Development Department.
- Relevant British standards insofar as the relevant areas are not covered by these instructions.
- For Republic of Ireland, reference should be made to the current edition of IS813 (the relevant standards governing installation).

Failure to comply with the above could lead to prosecution and deem the manufacturer's warranty invalid.

This appliance must be installed in accordance with the rules in force and used only in a sufficiently ventilated space. The appliance is designed to fit various types of situations as described in sections 3.0 and 4.0. The appliance must be installed in a correctly sized room (see section 3.1), and the correct purpose provided ventilation must be provided (see section 4.1). It should be noted that heaters create warm air currents. These currents move heat to wall surfaces next to the heater. Installing the heater next to vinyl or cloth wall coverings or operating the heater where impurities in the air (such as tobacco smoke, candle smoke etc.) exist, may cause the walls to become discoloured.

This appliance is intended as a secondary source of heat only and should not be used in a room without some form of background heating present. If the appliance is used in a room as the sole source of heat, then condensation may occur on colder surfaces within the room.

On first light up of a new appliance, initial curing of high temperature paint and burning off of lubricants may occur for the first few hours of operation. During this period some smoke may be emitted from the outlet grille, this should be no cause for concern. Accordingly, the room should be well ventilated with all windows and doors open during this period. During this period the appliance may cause smoke alarms to sound. If this happens, reset the alarms, but do not remove the batteries.

Consult ALL instructions before installation and use of this appliance. This appliance is free from any asbestos material.

## 2.0 APPLIANCE DATA

	<u>Novo Inset</u>
Gas Group	G20 Natural Gas CAT I2H
Inlet Pressure ( $\pm$ 2.0mbar)	20 mbar
Regulator Pressure	N/A
Max Energy Input (Gross)	2.3 kW
Max Energy Input (Net)	2.07 kW
Max Gas Rate	0.23 m <sup>3</sup> /h
Min Energy Input (Gross)	1.3 kW
Min Energy Input (Net)	1.17 kW
Min Energy Input (Gross)	166 W
Min Energy Input (Net)	150 W
<u>Burner Pressures -</u>	
High Cold ( $\pm$ 1.5 mbar).	18.0 mbar
High Hot ( $\pm$ 1.5 mbar).	18.2 mbar
Low Cold ( $\pm$ 0.75 mbar).	4.5 mbar
Low Hot ( $\pm$ 0.75 mbar).	4.6 mbar
Flow restrictor orifice	1.16 mm
Injector	N/A
Oxypilot (SIT/Bray)	9110
Gas control	BM733
Gas Inlet restrictor elbow	8mm
Ignition	Piezo spark
Spark Gap ( $\pm$ 1.0mm)	4.0 mm

## 3.0 INSTALLATION REQUIREMENTS

The fire has been designed to be installed in two main applications; either to fit into a suitable opening created in the inner leaf of an outside wall or false chimney breast/extended fire surround built to conceal the appliance. The appliance can also be fitted into an unserviceable or inoperative fireplace served by a natural draught flue but the old flue must be sealed off. It will be necessary to ventilate the old flue to prevent condensation and dampness forming, however any air vent used to ventilate the old flue must not be sited within 500mm of this appliance. If the flue can be ventilated to the outside of the building then this is usually the best solution. If in doubt then advice should be sought from a local building control officer.

The appliance must be installed onto a suitable non-combustible insulating surface at least 12 mm thick covering the entire base area of the box. The fire must be used with a back panel capable of withstanding 150°C minimum. Any combustible materials directly behind the fire frame (or back panel) and close to the cavity box of the fire must be removed and replaced with non-combustible material such as cement, browning, 'Superlux' board or equivalent materials.

### 3.1 ROOM SIZING

The room size should be a minimum of 27m<sup>3</sup> (e.g. 11' x 11' x 8') to allow adequate circulation of air and ensure the correct operation of the fire. This volume may include adjacent spaces but these spaces must not be separated by a door. To calculate a room size in cubic metres (m<sup>3</sup>) divide the room volume in cubic feet (ft<sup>3</sup>) by 35.3.

### 4.0 SITE REQUIREMENTS

This appliance may be installed in any room in the home except bathrooms or bedrooms. Installation in living rooms is common, however other rooms such as kitchens, dining rooms and hallways are permitted, providing a suitable natural gas supply is available, and rooms sizing and ventilation requirements are strictly adhered to (see sections 3.1 and 4.1).

The appliance is designed to be versatile, and as such will operate correctly when exposed to normal gentle draughts experienced within the home. It is not recommended, however that the appliance be installed in areas where it is likely to be exposed to persistent strong draughts, that may be generated by outside doors or windows, air vents etc. It is recommended that the appliance should not be installed within 1 metre of any air vent.

## 4.0 SITE REQUIREMENTS (continued)

### Basic opening sizes (all dimensions in mm)

The basic opening dimensions for the appliance are as follows;

Dimension:	Novo Inset
'a' minimum	560
'a' maximum	610
'b' minimum	410
'b' maximum	470
'c' minimum	105
'c' maximum	None
'd' minimum	50
'e' minimum	560
'f' minimum	140
'g' minimum	560
'g' maximum	As desired
'h' minimum	655
'h' maximum	As desired
'i' minimum	560
'i' maximum	610
'j' minimum	410
'j' maximum	470
'k' minimum	245
'k' maximum	None

Table 1

The opening must be within these sizes in order to accommodate the full depth of the fire box in non-combustible applications. Applications involving combustible materials e.g. timber battens in false chimney breasts, must use appropriate clearances and insulation methods as described in the relevant section of these instructions. Opening depth 'c' includes any plaster, cement or infill/back panels that form part of the installation.

Consideration for cable fixings, any hearth that may be required etc. should be made in addition to the basic sizes given in table 1.

- Cable fixings at rear - allow an extra 20mm depth.
- Hearth to be installed - allow the height of the hearth (minimum 50mm).

The appliance must be sited on a solid base (indicated in figure 1). This base may be combustible (i.e. laminate or wooden flooring) but must not be carpet or fabric of any kind. If the room in which the appliance is to be installed is carpeted or has a fabric floor covering then a small solid hearth will be required, meeting the dimensions specified in table 1 and illustrated in figure 2.

In all installations, the wall or back panel of the installation must be flat, non-combustible and meet the dimensions specified in table 1 and illustrated in figure 2.

The appliance may be installed as a 'hole in the wall' type installation, however a small hearth or ledge must be provided to support the base of the appliance and decorative fascia. In this situation the thickness of the hearth or ledge may be as desired, but it must have the strength to support the weight of the appliance and the fascia.

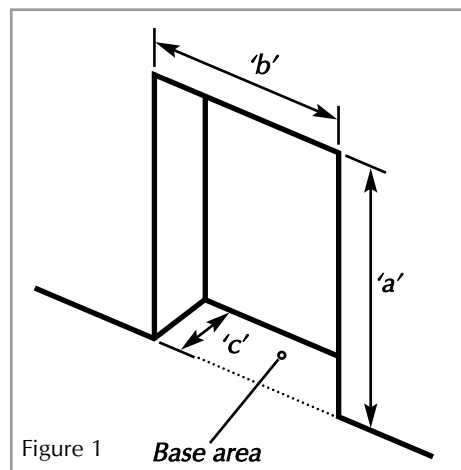

Figure 1

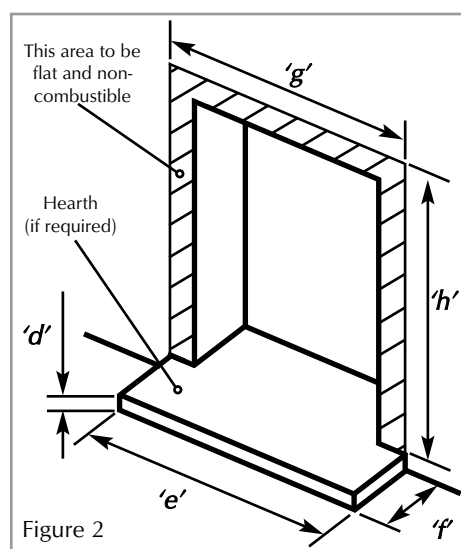

Figure 2

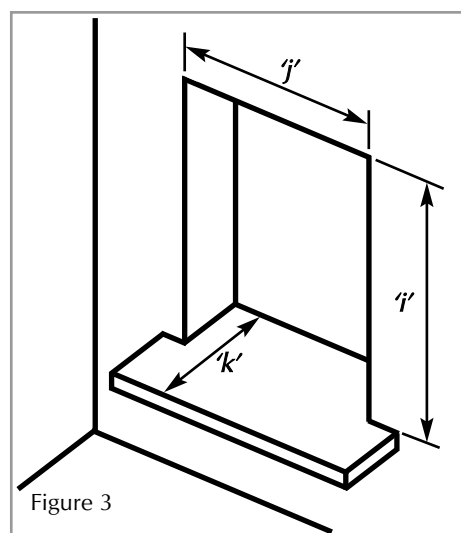

Figure 3

## 4.0 SITE REQUIREMENTS (continued)

### Clearances to non-combustibles

Non combustible surfaces are defined as brick, metal, marble, concrete etc. and also a number of man-made materials impervious to flame. If in doubt refer to the material manufacturer for further information before proceeding with installation.

The wall/back panel for the opening must always be non-combustible. Bare plasterboard must be protected by non-combustible plaster or replaced with non-combustible material (e.g. Superlux board). Any gap between wall boards and the wall must be filled using glass fibre insulation, silicone mastic or similar material to prevent heat ingress.

Any type of fire surround used with this appliance must be adequately sealed to the wall and floor to prevent excess draughts around the back of the fire. The temperature rating of any surround used must be 150°C minimum.

Clearances to the sides of the appliance are 100mm (4"). Clearance to the front of the appliance is 500mm (20").

The sides and back of the appliance may be installed directly onto a non-combustible surfaces.

A non combustible shelf of any depth may be positioned above the appliance provided it is no closer than 200 mm from the top of the appliance glass panel and the wall above the appliance is non combustible. The shelf itself and any articles placed on it must also be tolerant of high temperatures.

### Clearances to combustible materials

Combustible materials are defined as wood, fabrics, or other materials likely to combust if exposed to flame. Generally, any material, which is likely to discolour, melt or misshape when exposed to moderate heat, should be considered as a combustible material or surface.

Clearance to the sides of the appliance facia are 100mm (4") but curtains, drapes and other fabrics are not permitted within a distance of 500mm (20") of the appliance sides. No such materials are permitted directly above the appliance regardless of distance.

The minimum clearance to the ceiling above the appliance is 800mm (31.5") measured from the top of the appliance glass panel.

Combustible materials should not be positioned directly in front of the appliance within a distance of one metre.

A combustible shelf may be fixed to the wall above the fire, providing that it complies with the dimensions given below.

<i>Maximum depth of shelf</i>	<i>Minimum distance from hearth to underside of shelf</i>
150mm	950 mm
100mm	850 mm

The shelf depth may be greater but the height must also be increased accordingly. An increase in height of 25 mm is required for every 12.5 mm of additional shelf depth. For shelves that are too low protective devices can be used such as metal heat deflectors, but it must be assured that the shelf does not reach an unacceptable temperature before relying on such a solution.

Under no circumstances should any electrical equipment e.g. plasma screen TV sets etc. be positioned on the wall above the appliance.

Clearance to the sides and rear of the firebox are a 75mm (3") air-gap. Clearance to the top of the firebox is a 100mm (4") air-gap.

It should be established that any mirrors or picture frames etc. to be positioned on the wall above the appliance are able to withstand prolonged exposure to moderate heat and moisture before proceeding with their installation.

If the appliance is to be mounted on a dry lined wall or a timber framed construction wall then the integrity and ability of the wall to carry the weight of the appliance must be confirmed. It is important in these circumstances that any vapour control barrier is not damaged, and that any structural members of the house frame are not damaged - refer to section 6.5.

## 4.1 VENTILATION

A minimum of 100 cm<sup>2</sup> purpose provided ventilation is required for this appliance. This may be achieved either with one vent 100 cm<sup>2</sup> at a high or low position in the room, or split ventilation i.e. 50cm<sup>2</sup> be installed at high level and 50cm<sup>2</sup> be installed at low level within the room. An openable window or equivalent is also required.

To reduce the possibility of draughts, road noise or insects entering the room via the air vent, we recommend the use of “Black Hole”, “Vortex” or “Centurion” type vents featuring internal baffles. The requirements of any other gas, oil or solid fuel appliances operating in the same room or space must be taken into consideration when assessing ventilation.

Any ventilation fitted must comply with BS 5871 part 2 and BS5871 part 4.

Ventilation fitted under, or within immediate vicinity of the appliance must not be used as it may adversely effect performance of the ODS system. For Republic of Ireland refer to the current edition of IS813 and any relevant rules in force. The appliance shall not be installed within one metre of any existing air vent, and any new air vent shall not be installed within one metre of the appliance.

## 5.0 UNPACKING THE APPLIANCE

Lift off the remaining packaging components. Check that the components supplied correlate with the component checklist. Please dispose of all the packaging materials at your local recycling centre.

### 5.1 COMPONENT CHECKLIST

QUANTITY	DESCRIPTION
1	Firebox and burner assembly
1	Set of manufacturer’s instructions
1	Cast ‘Novo’ fascia and ashpan
1	Rubber grommet
1	Cable fixing kit
1	Screw pack including wallplugs

## 6.0 APPLIANCE INSTALLATION

**Note: Ensure that the gas supply is isolated before commencing installation of the appliance.**

The fireplace opening and environment must be in compliance with specifications laid down in the appropriate sections of these instructions.

### 6.1 PREPARING THE APPLIANCE

Remove the appliance from its carton as described previously and stand on a dustsheet. Remove the hood and glass panel and place safely to one side.

Knock out holes are provided in the rear and sides of the firebox for use where concealed pipework is required. Note: Knock out holes are also provided in the sides of the inner firebox if a side-entry pipe routing is required, but it is essential to seal these holes with grommets. Knock out the appropriate hole in the cavity box with a sharp tap from a hammer and fit the rubber grommet supplied. A small incision can now be made in the rubber to slip snugly around the outside of the supply pipe and sleeving.

**Warning : Do not install or use the appliance without this seal in place.**

## 6.2 GAS SUPPLY ROUTES

Following preparation of the fixing method, the concealed gas supply (if required), can now be installed. When the opening is ready for installation the gas supply can be routed. If the gas pipe has been sleeved the ends of the sleeving must be sealed. The end of the 8mm pipe should be temporarily sealed to prevent the ingress of debris during fixing.

An inlet restrictor elbow is supplied as part of the appliance.

All installation pipework must be in accordance with the current edition of BS 6891, and for timber framed dwellings, the current edition of IGE/UP/7.

In order to avoid unnecessary pressure drops, no more than 1.5m of 8mm diameter pipe must be used. If a concealed gas connection is to be made, the supply pipe should always be sleeved through walls and floors using the shortest possible route. For concealed supply pipe routing, pipes must (where possible) be vertical and providing there is sufficient wall thickness available, they should be placed in pipe chases. Horizontal pipe runs should be avoided. Prior to chasing a solid wall, an inspection should be made to note the proximity of any cables/sockets outlets which may already be buried. Pipes must be secured using suitable clips and protected against corrosion. Ideally factory finished protected pipework and fittings should be used. Joints should be kept to a minimum and compression fittings must not be used. The pipework installation must be tested for tightness before any protection is applied and/or the pipework and fittings are buried.

## 6.3 INSTALLATION METHOD 1 (against a non-combustible inside wall)

This method requires no modifications to the internal wall of a property and is achieved by using either a surround with extended rebate or a false chimney breast of minimum 105mm internal depth. If cable fixings are to be used then the minimum depth should be 125mm.

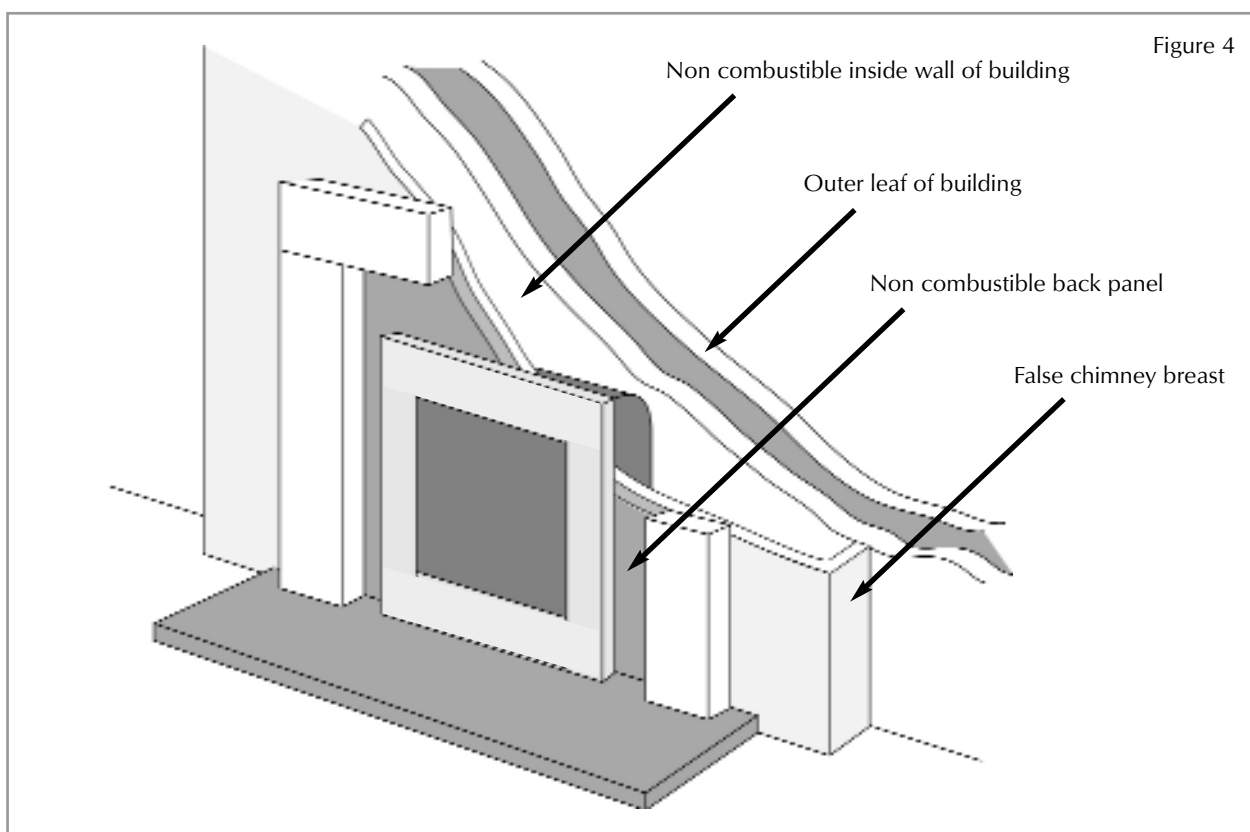

A false chimney breast should be installed, taking into account any guidance given in the section on timber framed buildings as far as insulation and clearances are concerned. When the false chimney breast is constructed from combustible materials the firebox must be separated from any combustible materials by a minimum 75mm air gap at the sides and rear and 100mm air gap above the firebox. Alternatively the firebox may be insulated with 75mm of fibre glass wool or rock wool to the sides, rear and 100 mm to the top.

## 6.4 INSTALLATION METHOD 2 (recessing into a non-combustible wall)

This method allows for installation of the appliance with the rear of the firebox recessed into the inner leaf of a cavity wall. This should enable a standard fire surround and back panel/hearth set to be fitted to the wall with the fire presented naturally in a flush fitted manner. The structural integrity of the wall must be maintained.

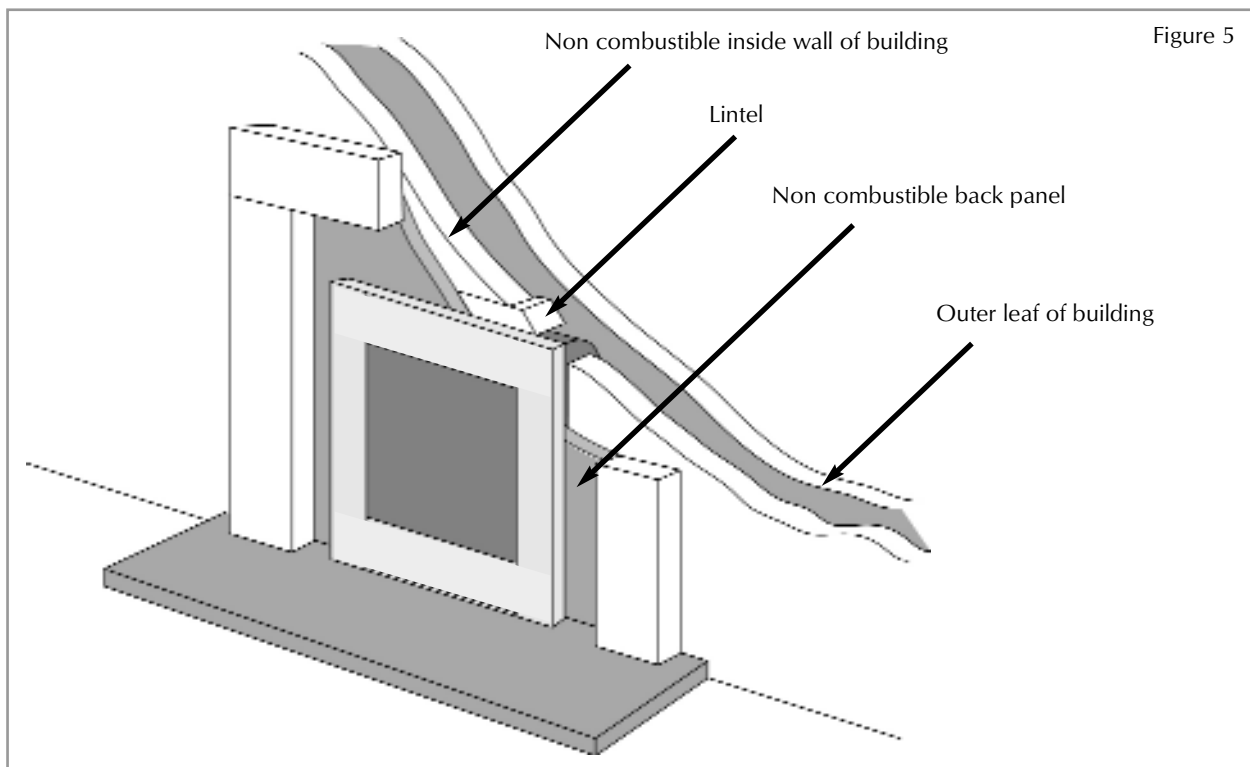

Figure 5

Check the cavity insulation type (if applicable). If cavity insulation is of a loose fill variety, take precautions to prevent excessive loss of material when the inner leaf is opened up by packing the cavity firmly with a minimum 50mm of rockwool or glass fibre. This will hold back any loose material now or in the future.

To maintain the structural integrity of the wall it is recommended that a suitable lintel is fitted. It is sometimes possible to install this appliance without a lintel, depending on the type of wall. The guidance of a qualified professional or local building control officer is essential to confirm this.

Mark out the area of the proposed fireplace opening on the wall. Obtain a suitable concrete or steel lintel from a builder's merchant. Drill four holes at the corners of the lintel position and squarely over the fireplace opening, and if possible centrally under a block joint. Clear out the block work in the area and insert the lintel by saw, or stitch drill and chisel. Do not dry bed the lintel - always bed on mortar and securely slate pin. Clear out the block work from below the lintel to form the opening for the firebox to be inserted.

The top of the exposed area of cavity must be sealed against the ingress of moisture dripping from above. The best way to do this is a cavity tray but an easier and quicker method is to affix a 'Supalux' or equivalent board into the cavity. Slope the board towards the outside wall and support with screws, cement, 'Unibond' or silicone mastic etc. This will guide all moisture, harmlessly, to the outside wall. The exposed sides of the cavity must be packed with a suitable depth (minimum 50mm) of glass fibre or rock wool to prevent draughts and heat loss, even if no loose fill material is present. It is good practice to insulate the rear of the fire from the cavity to prevent heat loss and condensation.

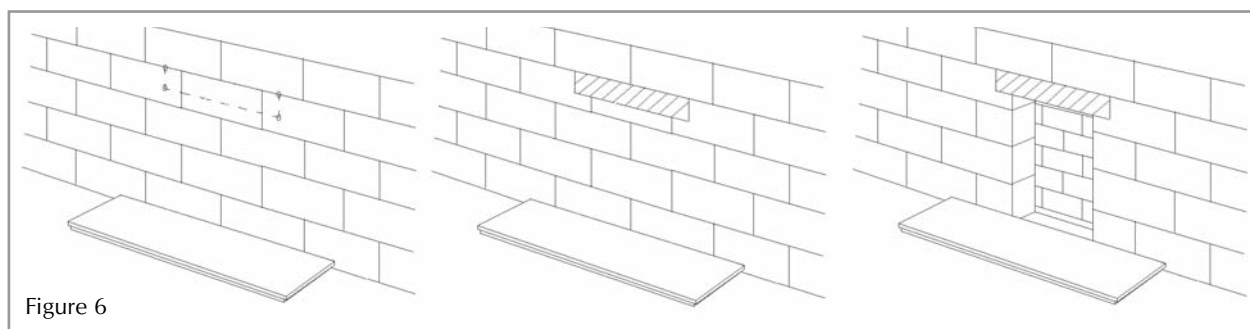

Figure 6

The hearth may now be put in place (If fitted). Again this should not bridge the cavity where it projects into the wall space. Finally install the fireplace or fire surround and back panel/marble to its finished location.

## 6.5 INSTALLATION METHOD 3 (timber framed buildings)

Where removal of any part of a timber frame is undertaken the structural integrity of the wall must be retained. The advice of your local building control officer should be sought. If the property is under any NHBC warranty it is also advised that their advice on this kind of modification is sought.

Either of the two preceding installation methods may be adapted for timber framed buildings, providing extra care is taken in ensuring combustible materials are adequately protected from the effects of heat.

The appliance must be installed in accordance with the British Gas documents DM2 and DM3 or the Institute of Gas Engineers published procedure document IGE/UP/7.

Special attention must be paid to the location of studwork frames of the inner leaf and the appliance positioned accordingly. Wires and pipes that run within the wall must also be taken into account.

### Installation as per method 1 (against inner wall)

When using this method of installation the following amendments should be incorporated. A 75mm air gap or 75mm of insulation (e.g. rockwool) must be provided between combustible materials and the sides and rear of the cavity box. A 100 mm air gap or 100mm of insulation (e.g. rockwool) must be provided to the top of the cavity box. It is also a good idea to enable as much airflow as possible, into and out of the area behind the fire without excessive heat loss from the room when the fire is off.

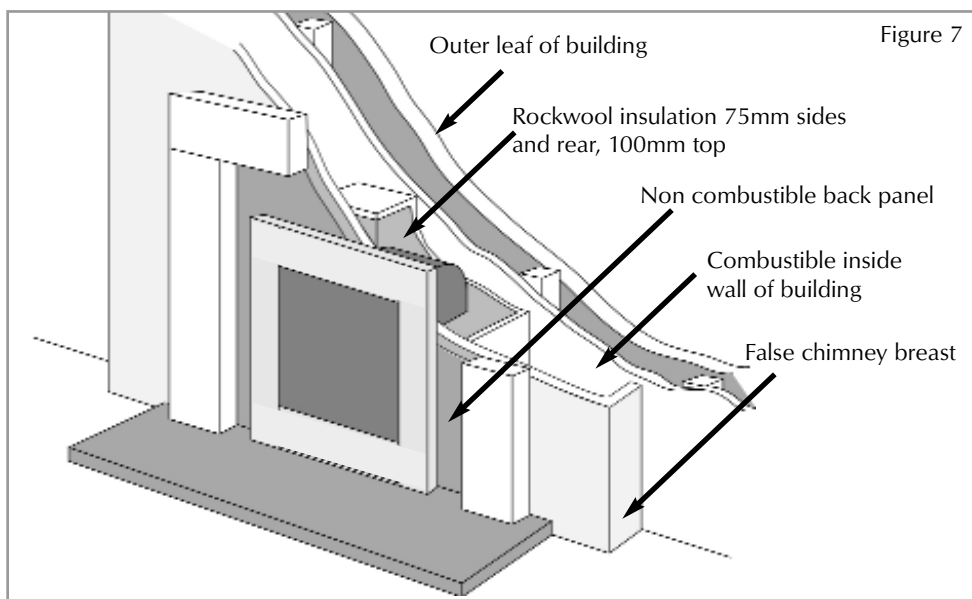

### Installation as per method 2 (recessing into a wall)

When setting the appliance into the wall find a suitable position between frame timbers and open up the hole. Secure back the damp proof membrane to prevent ingress of damp. Again 50mm insulation plus a 12mm thick fire retardant board, 'Superlux' or equivalent, must be provided between combustible materials and the sides and rear

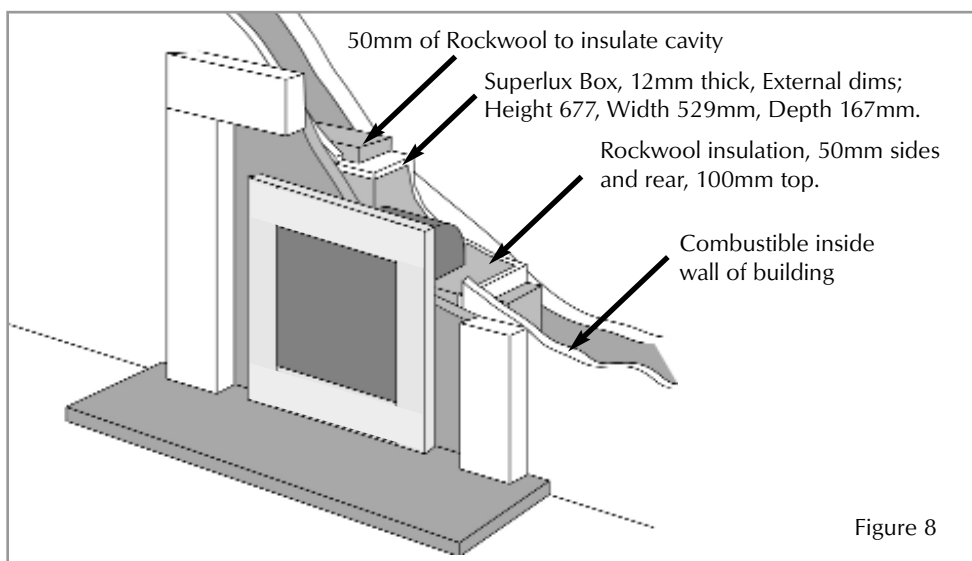

of the cavity box. 100 mm of insulation plus a 12 mm thick fire retardant board, 'Superlux' or equivalent, must be provided to the top of the cavity box. The exposed cavity should be sealed off using non-combustible board, ('Supalux' or equivalent), made into a 4-sided box. It is also good practice to further insulate the cavity with a 50mm layer of Rockwool outside the Superlux box. Note that the appliance should not be allowed to bridge the cavity in this installation method. It is also a good idea to enable as much airflow as possible, into and out of the area behind the fire without causing excessive heat loss from the room when the fire is off.

## 6.6 INSTALLATION METHOD 4

This method allows for a 'hole in the wall' installation of the appliance with the rear part recessed into the inner leaf of a cavity wall. The structural integrity of the wall must be maintained. The wall must be non-combustible.

Refer to section 6.4 (recessing into a non-combustible wall).

**Novo models :** If the appliance is to be wall mounted then the entire base of the appliance must be supported by a non-combustible shelf. The dimensions of such a shelf are given in section 4.0 (site requirements).

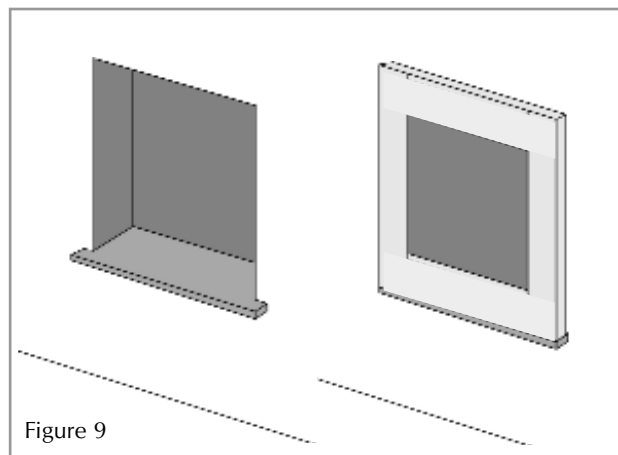

Figure 9

## 7.0 FINAL FITTING

If not previously carried out, insert the firebox into the opening. If the appliance is to be screw fixed to the back panel/wall or inside of the opening then suitable locations for such fixings should be established, and a suitable number and type of such fixings should be established to ensure the appliance is securely fixed.

There are no purpose provided screw fixing points provided on the firebox as the location of these points will vary from installation to installation, depending on the strength of the surrounding materials and the various sizes of opening that the appliance may be required to fit into. A cable fixing kit, however, is provided and should be used wherever possible as the default fixing method.

Carefully insert the firebox into the opening and guide the gas pipe through the sealing grommet into its final routing position and fit the restrictor inlet elbow supplied to the gas pipe. Secure the firebox by inserting screws in the previously prepared locations (if screw fixing) or refer to the following section if cable fixing.

## 7.1 CABLE FIXING

When using this method for fixing, the minimum depth of the opening must be increased from 105 mm to 125 mm. This is to allow for the eyebolts and a space for the cable tensioning. Remove the appliance glass panel by removal of the four retaining screws. Remove the burner unit - refer to section 9.2.

Drill four holes to a depth of 42mm, using a 8mm drill bit, in the positions shown in figure 11 and fit the wallplugs. If the fireplace does not allow for the exact layout shown, the eyebolts should be fixed to give as similar a configuration as possible. Thread both tensioning cables through the holes in the protruding tabs on the rear of the firebox then through the eyelets and back through the lower holes in the firebox.

Push the firebox back into the fireplace, centralise, pull the loose cables through the holes and into the bottom of the cavity box. Thread the cable tensioners onto the cables with the nuts screwed down close to the tensioner head. Slide the screwed nipple onto the cable, pull cable taut and tighten nipple. Adjust tensioner using a suitable spanner to pull the appliance back into position, to allow an even pull around the fireplace opening. Visually inspect and repeat if necessary to achieve a good fit.

**Note: Surplus cable MUST NOT be cut off, as this will prevent proper re-installation after servicing. Coil up the surplus cable and tuck the coils out of the way.**

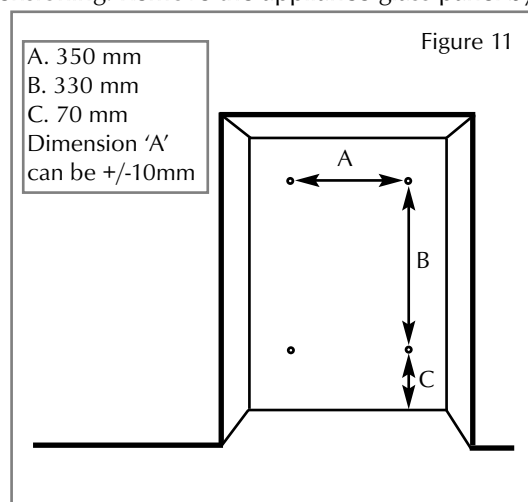

Figure 11

## 7.2 CHECKING THE BURNER AND SPARK GAP

**Contemporary models :** There are no imitation fuel bed components to install. The appliance features a ribbon burner which is designed to produce a continuous band of flame over its length. The burner should be visually inspected to ensure it is free from any foreign matter.

If it is necessary to clean or dust off the burner then (if fitted) the glass door should be removed by removal of the four retaining screws. Re-fit the glass door after cleaning or inspection, ensuring a good seal.

**Coal effect models :** The burner should be visually inspected to ensure it is free from any foreign matter. If it is necessary to clean or dust off the burner then (if fitted) the glass door should be removed by removal of the four retaining screws. Fit the fuel bed as described in section 7.3.

**All models :** The gap between the spark electrode and the pilot should be 3 - 5mm to produce a good spark. There should be no need to adjust this. If under any circumstances the piezo electric spark fails, the pilot cannot be lit manually.

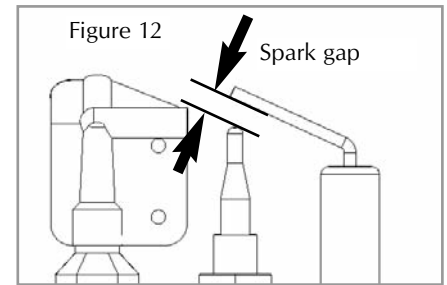

## 7.3 FITTING THE FUEL BED (Coal effect models only)

The appliance features a coal style fuel effect.

1. Place the rear coal strip onto the shelf behind the burner as shown in figure 14. Ensure that the four protruding screw heads engage the hollow areas on the underside of the piece.



2. Position the front coal piece onto the front of the burner as shown in figure 15.



Re-fit the glass panel using 4 M6 screws. The fire is designed to operate correctly with the supplied components according to the instructions. Never add coals. Never put combustible or non-combustible materials, rubbish or other matter into the fire.



## 7.4 FITTING THE DECORATIVE FRAME, FRONT AND HOOD

The appliance is supplied with a decorative frame and hood. Attach the hood using two M6 screws as shown in figure 16.

Remove all protective packaging from the frame. The frame is retained by four magnets on the front face of the firebox as shown in figure 17. Position the frame onto the magnets.

Figure 16

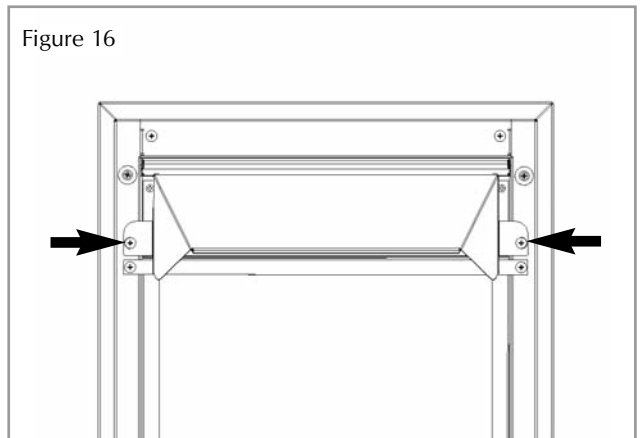

## 8.0 TESTING AND COMMISSIONING

Turn on and test the gas supply up to the fire for any leaks, in accordance with the current edition of BS6891.

### 8.1 OPERATING THE APPLIANCE

The control knob is supplied in the loose parts pack. Fit the control knob onto the valve spindle as shown in figure 18.

The pilot is visible behind the left hand side of the burner. Push in and turn the control knob to the SPARK position, and hold there for a few seconds. Continue turning anti-clockwise through the spark click to the PILOT light position, ensuring the pilot has lit. If not, return the knob clockwise, and repeat.

When the pilot lights after the spark, keep the knob depressed for approximately ten seconds. Now release the knob and the pilot should stay alight. If the pilot is extinguished during use, wait three minutes before repeating the ignition procedure.

To achieve the HIGH setting, push the control knob in slightly and continue turning anti-clockwise to the high position. The main burner should light after a few seconds. To decrease the setting to low, turn the control knob clockwise to the LOW setting.

Figure 17

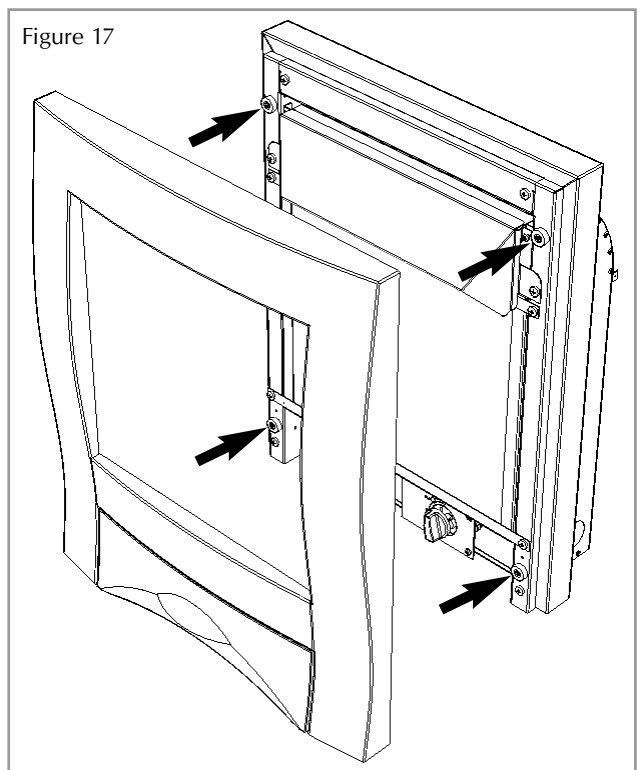
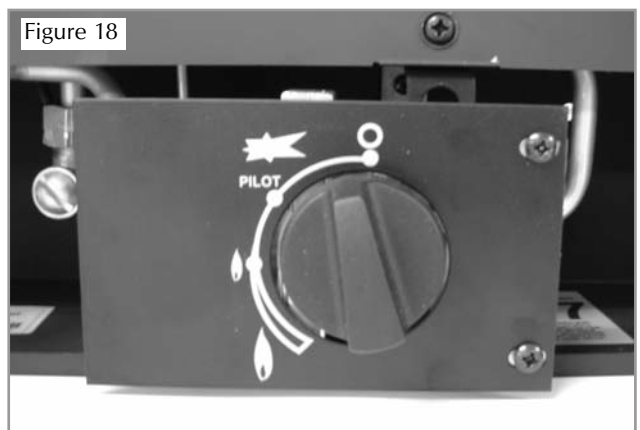

Figure 18



To turn to the PILOT position from the HIGH or LOW positions, press the control knob in, and return to the pilot position and release. To turn the fire off, keep the knob pressed in, return to the OFF position and release.

## 8.2 SETTING PRESSURE

The pressure test point is located on the left hand side of the appliance, on the main burner pipe, next to the brass restrictor/connector. Release the setting pressure test point screw (shown in figure 19), and attach a pressure gauge.

Light the fire on the HIGH setting.

To commission the appliance, the burner pressure must be in accordance with the figures stated in section 2.0 of these instructions. The fire is factory set to achieve these pressures and any significant variation could indicate a supply problem. If the pressure is too high, the gas supply meter may be set incorrectly. This should be checked with the fire running and if necessary reset by the gas supplier.

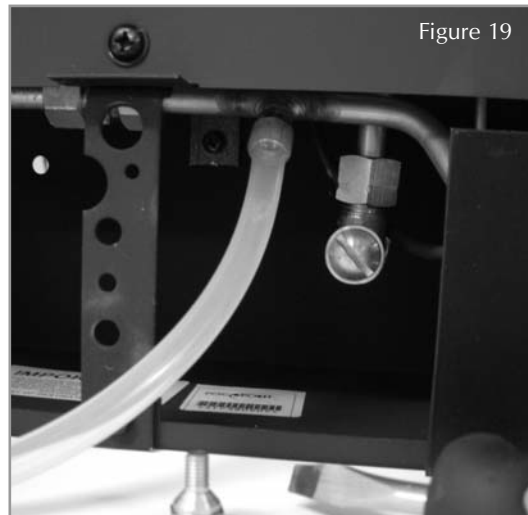

Figure 19

If the burner pressure is too low, then check the inlet pressure with the appliance running. If this is less than the inlet pressure stated in section 2.0 of these instructions it will need to be reset by the gas supplier. If the setting pressure is too low, but the meter pressure is acceptable, then a problem in the supply pipework is to be suspected.

Upon satisfactory checking of the burner pressure, turn the fire off, disconnect the pressure gauge and refit the test point screw. Light the fire and check for gas soundness.

In the event that the burner pressure is not in accordance with the figures stated in the data section of these instructions, the appliance must not be commissioned, and the manufacturer should be contacted for guidance.

## 8.3 BRIEFING THE CUSTOMER

All instructions must be handed to the user for safekeeping. Show the customer how to light and control the fire. After commissioning the appliance, the customer should be instructed on the safe use of the appliance and the need for regular servicing. Frequency of service depends on usage, but **MUST** be carried out at least once annually. Advise that cleaning of the fire may be achieved when the fire is cold using a damp cloth and mild detergent on most surfaces. Advise that the fire will emit a "newness" smell for a time after initial commissioning and that extra ventilation may be needed during this time. Recommend that a guard be used for the protection of young children, pets, the elderly and the infirm.

## 9.0 SERVICING

Isolate the fire from the gas supply. Ensure that the fire is fully cold before attempting service. A suggested procedure for servicing is detailed below.

1. Lay out the dustsheet and tools.
2. Remove the hood (two M6 screws) and front and frame/facia.
3. Remove the glass door assembly (four M6 screws) and clean carefully.
4. Carefully remove the ceramic components (where supplied).
5. Inspect the catalyst and clean if necessary with a soft brush.
6. Disconnect the gas supply and remove the four screws retaining the burner (two in the burner legs and two in the rear of the firebox).
7. Lift away burner assembly.
8. Strip off the burner pipes and clean thoroughly.
9. Clean the in-line restrictor, pilot assembly and the burner tube. Do not attempt to remove the pilot injector as this can cause damage.
10. Re-assemble and re-fit the burner tray.
11. Turn on the gas supply and leak test. Check pilot and burner for good ignition.
12. If applicable, refit the ceramics as per these installation instructions.
13. Refit the glass door assembly, ensuring a good seal.
14. Refit the hood, front and frame/facia.
15. Check any purpose provided ventilation is un-obstructed.
16. Light the fire and check setting pressures.
17. Carry out combustion check as per section 9.4.
17. Check safe operation of the appliance.

For specific servicing instructions, see relevant sections.

## 9.1 CLEANING THE CERAMICS (where applicable)

Remove the fire front and place to one side. Remove the hood. Remove the glass door assembly. Remove the ceramic components. Gently clean in the open air with a soft brush. Be careful not to create dust from the ceramics. Where necessary replace damaged components with genuine spares. Seal scrap ceramic components in plastic bags and dispose at proper refuse sites as directed. If using a vacuum cleaner a HEPA filtering system is recommended.

Re-fit the ceramics by referring to the relevant section of these instructions. Refit the glass door assembly ensuring a good seal. Refit the hood.

## 9.2 SERVICING THE BURNER TRAY AND GAS ASSEMBLY

Firstly, remove the hood and front fret/facia, the glass panel, data plate and disconnect the gas connection at the isolator elbow. Remove the burner tray by removing the four securing screws shown in figure 20.

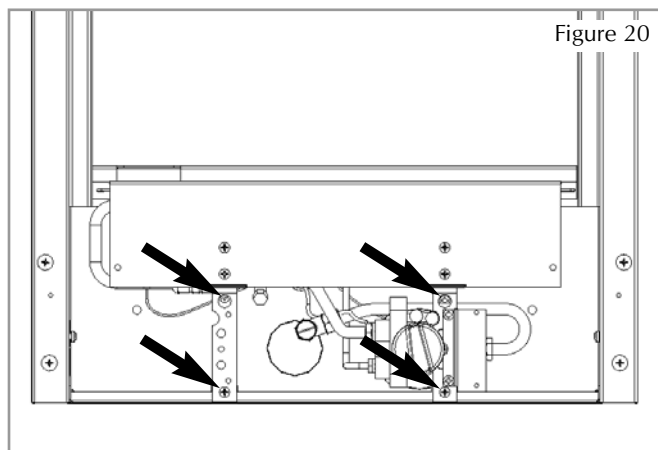

Remove the pilot and main burner pipes and blow through to dislodge any debris. Now remove the restrictor elbow and blow through to make sure it is entirely clear. Unclip the pilot lint gauze and clean with a soft brush.

Clean the exterior of the pilot assembly with a soft brush and blow through the flame ports on the pilot head. Check the aeration holes are free from lint or dirt. The pilot assembly can be removed if required by disconnecting the electrode HT lead, gas pipe and unscrewing the mounting screws and lifting away.

The pilot assembly is a non-serviceable item and should not be taken apart. Aeration holes must be absolutely clear internally for proper operation. **NEVER MODIFY OR BEND THE THERMOCOUPLE TO MAKE THE PILOT STAY ALIGHT.** Modifications are dangerous and can have serious unseen effects on safety. If the pilot will not stay lit there is a problem with dirt, the gas supply to it, or the thermocouple needs replacement.

The gas valve is a non-serviceable item. If this needs replacement, remove M4 securing screw holding the valve in place, remove all pipe unions, electrode lead, thermocouple lead and then the complete valve. Replacement must be original manufacturers parts. Re-assembly is the reverse of removal. Ensure setting pressures are as stated in Section 2; Appliance Data.

Re-assembly in the reverse of removal.

## 9.3 PILOT ASSEMBLY

Clean the pilot assembly with a soft brush and blow through. Check the aeration holes are free of any dirt or lint. Clean thoroughly internally, the connection can be removed from the base of the pilot unit using two spanners to make cleaning easier. Do not damage or try to dismantle the pilot injector.

The unit is factory set and the only check necessary is to ensure the spark gap is correct. See specifications for gas setting.

**NEVER MODIFY OR BEND THE THERMOCOUPLE TO MAKE THE PILOT STAY ALIGHT.** If the pilot will not stay lit there is a problem with dirt, the gas supply, or the thermocouple needs replacement. Modifications are dangerous and can have a serious unseen effect on safety and therefore **MUST** not be done. Replacements must be original manufacturers parts. Re-assemble in the reverse of removal. Ensure setting pressures are as stated in Section 2; Appliance Data.

## 9.4 CATALYST

It is recommended that the catalytic converter is inspected for signs of damage and dirt during routine servicing procedures. The expected life of the catalyst is in excess of 11,000 hours (10 years of normal use). After this time the catalytic converter should be replaced.

If there are any deposits of dirt or soot on the catalyst they should be cleaned with a soft brush and a vacuum cleaner. If removed for cleaning ensure the seals are in good condition before replacing the catalytic converter. New seals will usually be required.

The performance of the catalyst may be checked using an analyser as follows. Any analyser used should conform to BS7927 : 1998 + A1 : 1999 or BS EN 50379-3.

**Important: The temperature of the gases emitted by the catalytic converter is in excess of 400 °C. Measuring gas of this temperature may damage some types of gas analysers. If in doubt consult the equipment manufacturer.**

Position gas sample probe directly in front of the catalyst underneath the hood, in the centre of the upper firebox. Ignite the fire as per the operating instructions, and run at high setting for 15 minutes. Record the carbon dioxide (CO<sub>2</sub>) concentration and then the carbon monoxide (CO) concentration as displayed by the analyser - also noting the units in which the values are expressed.

Most analysers display carbon dioxide (CO<sub>2</sub>) concentrations in percentage (%) terms and carbon monoxide concentration in parts per million (ppm) terms.

In order to calculate the combustion ratio for the appliance (CO/CO<sub>2</sub>) it is first necessary to express both gas concentrations in terms of percentage. To convert from parts per million (ppm) to a percentage (%) divide the ppm figure by 10,000. Examples : 35ppm = 0.0035%, 15ppm = 0.0015%, 5ppm = 0.0005%.

Now divide the concentration of carbon monoxide (CO) expressed in percent by the concentration of carbon dioxide (CO<sub>2</sub>) to obtain the appliance combustion ratio.

$$\frac{\text{CO (\%)}}{\text{CO}_2 (\%)} = \text{ratio}$$

**The combustion ratio of the gasses emitted by the catalytic converter should not exceed 0.0015.**

If replacing the catalytic converter, remove the hood, front fret/face and the grille (as shown in figure 21). The catalytic converter retaining clamp is secured with 4 nuts and slip proof washers, located on the inside of the firebox, at the top, remove these nuts and the clamp can be removed. Withdraw the clamp, followed by the catalytic converter and its seals from the firebox and discard.

Refit a new catalytic converter and seal in reverse order.

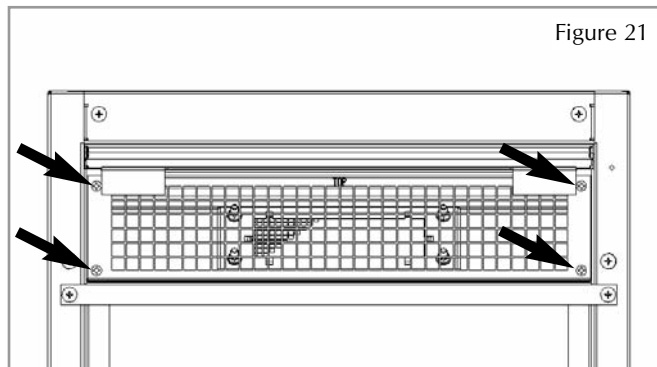

## 9.5 TESTING FOR FIREBOX LEAKAGE

Appliances that are several years old or have been extensively dismantled should be checked for soundness. It is important that all the products of combustion pass through the catalytic converter at the top of the firebox before leaving the appliance.

The firebox is heated by lighting for a few minutes to provide a flow through the firebox. The burner is then shut off and a smoke pellet or match introduced at the base of the fire underneath the burner tray. Large quantities of smoke will emerge from the top of the appliance, but none should emerge from the joints or gasket faces, especially around the door.

It is important to note that the appliance can never be expected to be 100% smoke tight and small quantities of smoke may be seen in corners of joints and gasket faces etc without affecting safety when the fire is in operation.

## 10.0 TROUBLESHOOTING GUIDE

Fire sparks but pilot does not light	No gas to fire - check isolators are open. Pipe work blockage or kink - rectify. Air not fully purged - re-purge supply or wait longer. Spark earthing to metal work - check gap is correct. Blocked pilot - check and replace where necessary.
Pilot lights but then goes out	Severe restriction in gas supply - clear obstruction. Faulty thermocouple - replace pilot unit. Blocked pilot - replace. Blocked lint gauze - clean. Hold control knob in for longer. Check the control knob does not foul on the data plate. If the pilot will not stay lit there is a problem with dirt, the gas supply, or the thermocouple is in need of replacement. Modifications are dangerous and can have a serious unseen effect on safety. <b>NEVER MODIFY OR BEND THE THERMOCOUPLE TO MAKE THE PILOT STAY ALIGHT.</b>
Fire does not spark at pilot	Electrode lead detached - refit. Spark gap too large or small - reset correctly. Faulty piezo unit - replace gas valve. Debris shorting out electrode - clean. Spark shorting to metalwork under tray - realign electrode lead.
Fire runs for a time and then cuts off	Check pilot has extinguished. Ensure room sizing and ventilation are adequate (See Section 3.1 and 4.1) Loose or faulty thermocouple - rectify. Blocked pilot - replace. Dirt or lint in pilot aeration hole or on the lint gauze - clean thoroughly. If the pilot will not stay lit there is a problem with dirt, the gas supply, or the thermocouple needs replacement. Modifications are dangerous and can have a serious unseen effect on safety. <b>NEVER MODIFY OR BEND THE THERMOCOUPLE TO MAKE THE PILOT STAY ALIGHT.</b>
Pilot flame shrinks when fire is on high	Poor gas flow to fire - check pressure with fire on high. If pressure is low - remove any restriction in pipework or valve. Check all isolators are adequately sized and fully open. Check meter pressure is adequate. If the pilot will not stay lit there is a problem with dirt, the gas supply, or the thermocouple needs replacement. Modifications are dangerous and can have a serious unseen effect on safety. <b>NEVER MODIFY OR BEND THE THERMOCOUPLE TO MAKE THE PILOT STAY ALIGHT.</b>
Fire smells when first lit or in use	Newness smell from brand new appliance. Leakage occurring - Carry out leakage test and rectify any problems. Low temperature sealants or combustible materials used in incorrect positions.

# USER INSTRUCTIONS

Section	Contents	Page No
1.0	Important Notes	1
2.0	Fire Front	2
3.0	Clearances to Combustibles	2
4.0	Ventilation and Room Size	3
5.0	Operating Instructions	3
6.0	Combustion Monitoring System	3
7.0	Fitting the Fuel Bed	4
8.0	Cleaning	4
9.0	Servicing	4
10.0	List of Replacement Parts	4

## 1.0 IMPORTANT NOTES

The installation and Servicing of this fire **MUST** only be carried out by a competent person (such as a Gas Safe registered fitter) in accordance with the Gas Safety (Installation and Use) Regulations 1998, the relevant British Standards, Codes of Practice, the Building Regulations and the manufacturer's instructions.

Failure to comply with the above could lead to prosecution and invalidate the appliance warranty.

Keep a note of the installer's name and address, Gas Safe registration number, the original purchase receipt and the date of installation (see section 9.0 of these instructions). Failure to produce this information may invalidate the warranty.

The appliance should be serviced regularly to ensure continued safe operation. See the servicing section for further reference.

Parts of this appliance become naturally hot during use. It is recommended that a suitable fireguard conforming to BS 8423 is used, especially where young children, pets, the elderly or infirm are concerned. The manufacturer of this appliance considers all surfaces as working surfaces with the exception of the control knob and control panel.

Combustible items, such as flooring and furniture and soft wall coverings (such as blown vinyl or embossed paper), low temperature surrounds etc may discolour if fitted too close to the fire. See relevant section for further details on clearances to combustibles. No combustible materials or flooring should protrude onto the hearth (if fitted).

This appliance incorporates a combustion monitoring system (ODS).

**DO NOT** burn any foreign material on this fire. Under no circumstances shall the appliance be used if the glass front door or panel has been removed, damaged or is open. Do not place any objects on top of the appliance.

The integral catalysts should be checked by the installer upon servicing to ensure there are no defects or obstructions that may prevent the satisfactory flow of combustion products. The expected life of the catalyst is in excess of 11,000 hours (10 years of normal use). After this time the catalyst should be replaced.

This appliance is only suitable for the gas type for which it is supplied.

**WARNING:** Due to the nature of this product the area around the top of the appliance (i.e. the grille) gets very hot. Care should be taken when operating the appliance.

## 2.0 FIREFRONT

This fire is supplied with a particular style of fire front. Use of the fire front will ensure an adequate airflow under the firebox for the correct functioning of this appliance. Compliance with safety standards cannot be guaranteed when another style of front is used.

## 3.0 CLEARANCES TO COMBUSTIBLES

### Clearances to non-combustibles

Non combustible surfaces are defined as brick, metal, marble, concrete etc. and also a number of man-made materials impervious to flame. If in doubt refer to the material manufacturer for further information before proceeding with installation.

The wall/back panel for the opening must always be non-combustible. Bare plasterboard must be protected by non-combustible plaster or replaced with non-combustible material (e.g. Superlux board). Any gap between wall boards and the wall must be filled using glass fibre insulation, silicone mastic or similar material to prevent heat ingress.

Any type of fire surround used with this appliance must be adequately sealed to the wall and floor to prevent excess draughts from around the back of the fire. The temperature rating of any surround used must be 150°C minimum.

Clearances to the sides of the appliance are 100mm (4"). Clearance to the front of the appliance is 500mm (20").

The sides and back of the appliance may be installed directly onto a non-combustible surfaces.

A non combustible shelf of any depth may be positioned above the appliance provided it is no closer than 200 mm from the top of the appliance glass panel and the wall above the appliance is non combustible. The shelf itself and any articles placed on it must also be tolerant of high temperatures.

### Clearances to combustible materials

Combustible materials are defined as wood, fabrics, or other materials likely to combust if exposed to flame. Generally, any material, which is likely to discolour, melt or misshape when exposed to moderate heat, should be considered as a combustible material or surface.

Clearance to the sides of the appliance facia are 100mm (4") but curtains, drapes and other fabrics are not permitted within a distance of 500mm (20") of the appliance sides. No such materials are permitted directly above the appliance regardless of distance.

The minimum clearance to the ceiling above the appliance is 800mm (31.5") measured from the top of the appliance glass panel.

Combustible materials should not be positioned directly in front of the appliance within a distance of one metre.

A combustible shelf may be fixed to the wall above the fire, providing that it complies with the dimensions given below.

<i>Maximum depth of shelf</i>	<i>Minimum distance from hearth to underside of shelf</i>
150mm	950 mm
100mm	850 mm

The shelf depth may be greater but the height must also be increased accordingly. An increase in height of 25 mm is required for every 12.5 mm of additional shelf depth. For shelves that are too low protective devices can be used such as metal heat deflectors, but it must be assured that the shelf does not reach an unacceptable temperature before relying on such a solution.

Under no circumstances should any electrical equipment e.g. plasma screen TV sets etc. be positioned on the wall above the appliance.

Clearance to the sides and rear of the firebox are a 75mm (3") air-gap. Clearance to the top of the firebox is a 100mm (4") air-gap.

It should be established that any mirrors or picture frames etc. to be positioned on the wall above the appliance are able to withstand prolonged exposure to moderate heat and moisture before proceeding with their installation.

## 4.0 VENTILATION AND ROOM SIZE

Purpose provided ventilation of 100cm<sup>2</sup> is required for this appliance. An openable window or equivalent is also required. Any ventilation fitted must comply with BS 5871 part 4 and BS 5440 part 2. Ventilation fitted under, or within immediate vicinity of the appliance must not be used as it may adversely effect performance of the combustion monitoring system (ODS) system. The appliance shall not be installed within 1 metre of any existing air vent, and any new air vent shall not be installed within 1 metre of the appliance.

The requirements of other appliances operating in the space or room must be taken into consideration when assessing ventilation requirements, this will have been carried out by your Gas Safe registered installer. A supply of fresh air into the room is advisable to maintain temperatures within limits.

This appliance must not be installed in a bedroom or a bathroom. For Republic of Ireland, see relevant rules in force.

The room size should be a minimum of 27m<sup>3</sup> (e.g. 11' x 11' x 8') to allow adequate circulation of air and ensure the correct operation of the fire. This volume may include adjacent spaces but these spaces must not be separated by a door. *Note* : To calculate a room size in cubic metres (m<sup>3</sup>) divide the room volume in cubic feet (ft<sup>3</sup>) by 35.3.

It should be noted that heaters create warm air currents. These currents move heat to wall surfaces next to the heater. Installing the heater next to vinyl or cloth wall coverings or operating the heater where impurities in the air (such as tobacco smoke, candle smoke etc.) exist, may cause the walls to become discoloured.

This appliance is intended as a secondary source of heat only and should not be used in a room without some form of background heating present. If the appliance is used in a room as the sole source of heat, then condensation may occur on colder surfaces within the room.

## 5.0 OPERATING INSTRUCTIONS

The control knob is marked as shown in figure 1. The pilot is visible behind the left hand side of the burner. Push in and turn the control knob to the SPARK position, and hold there for a few seconds. Continue turning anti-clockwise through the spark click to the PILOT light position, ensuring the pilot has lit. If not, return the knob clockwise, and repeat.

When the pilot lights after the spark, keep the knob depressed for approximately ten seconds. Now release the knob and the pilot should stay alight. If the pilot is extinguished during use, wait three minutes before repeating the ignition procedure.

To achieve the HIGH setting, push the control knob in slightly and continue turning anti-clockwise to the high position. The main burner should light after a few seconds. To decrease the setting to low, turn the control knob clockwise to the LOW setting.

To turn to the PILOT position from the HIGH or LOW positions, press the control knob in, and return to the pilot position and release. To turn the fire off, keep the knob pressed in, return to the OFF position and release.

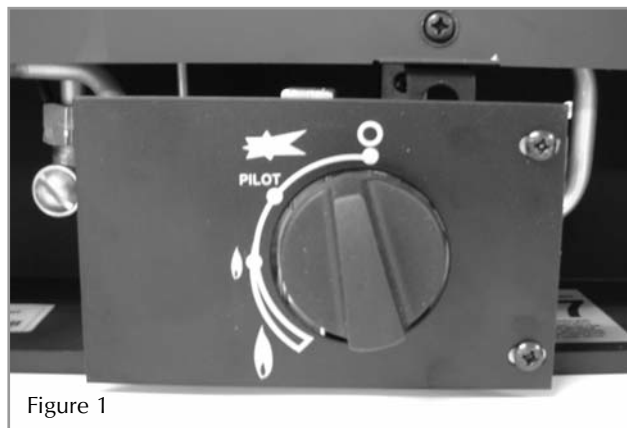

Figure 1

## 6.0 COMBUSTION MONITORING SYSTEM

This fire is fitted with a combustion monitoring safety device (ODS). If the fire shuts down during use for no apparent reason then several reasons may be suspected. If a door or window has been opened creating a draught, then pilot disturbance could be the problem and removal of the draught should resolve this. The fire can then be re-lit in accordance with the previous section. A grommet seal may also be missing from the fire-box causing abnormal draught to shut down the pilot. Call your installer to check seals are properly fitted.

If pilot disturbance is not the cause, then the ODS safety system may be in operation. Switch the appliance OFF, call in your installer to check the appliance and ventilation. Remedial work must be carried out as required. DO NOT allow the appliance to be used until the appliance and installation is passed as safe. If the pilot continues to be extinguished you must call your installer to check the operation of the complete appliance.

## 7.0 FITTING THE FUEL BED (Coal effect models only)

The appliance features a coal style fuel effect.

1. Place the rear coal strip onto the shelf behind the burner as shown in figure 2. Ensure that the four protruding screw heads engage the hollow areas on the underside of the piece.



Figure 2

2. Position the front coal piece onto the front of the burner as shown in figure 3.



Re-fit the glass panel using 4 M6 screws. The fire is designed to operate correctly with the supplied components according to the instructions. Never add coals. Never put combustible or non-combustible materials, rubbish or other matter into the fire.



Figure 3

## 8.0 CLEANING

Before carrying out any of the following operations, ensure that the appliance is OFF and completely cold. Regularly clean around the appliance to ensure that dust, fluff, pet hair etc, are kept to a minimum. There are no other specific requirements for care, other than regular cleaning of the general appliance. A wipe with a dry cloth is normally sufficient. **DO NOT** use abrasive cleaners as they can damage the finish. Metal parts may be cleaned using an appropriate metal cleaner or baby oil. Test on a hidden part of the aluminium before cleaning. Clean only in the direction of the grain.

GLASS PANEL - This can be cleaned with a suitable glass cleaner. Test on a small area first.

PAINTED AREAS - These can be cleaned using a dry cloth.

FINISHED METAL AREAS - These can either be cleaned using a proprietary metal cleaner or baby oil. Test on a small hidden part before cleaning. Always clean in the direction of the grain.

## 9.0 SERVICING

The appliance should be checked on an annual basis to ensure it is working safely and that there is no excessive build up of soot. The frequency of service will depend on usage, but **MUST** be carried out at least once annually. Servicing must be carried out by a competent person, such as a Gas Safe registered installer.

## 10.0 LIST OF REPLACEMENT PARTS

The Installation instructions carry full servicing details for the use of the installer.

PART NO.	ITEM
FB/F550272	Glass door assembly
FB/F550234	Hood
Please enquire	Decorative frame
FT/003155/0	Gas Valve
FT/F730023	Pilot assembly
FT/F510018	Burner unit (Coal version models)
FT/F510035	Burner unit (Contemporary models)
FB/F780079	Catalyst (seal kit must also be supplied)
IN/F940136	Seal kit for Catalyst